



Safety nets: Fall protection for the construction industry

There are two basic kinds of fall-protection systems in use in the construction industry, namely, passive and active systems. Passive systems, when installed, protect workers without the need for them to take positive action on their own behalf. Active systems, on the other hand, are protection systems or devices that require each worker to take positive action to protect against a fall, such as putting on a safety belt, connecting the belt or lanyard to a safe suspension point or putting on a hard hat, etc. This data sheet will deal only with safety nets for the safety of personnel who work on construction projects.

Passive protection net systems

2. Passive net systems consist of two major types: personal nets and debris nets. Personnel nets are designed to catch personnel who fall from a high place—a bridge, building, tower, dam, silo or other structure. Personnel nets are made of a variety of natural and synthetic materials in the form of rope or strips to produce a webbing that has a mesh strength strong enough to withstand the force of a falling person and a mesh size small enough to minimize personal injury. Details of personnel net specifications will be discussed later.

3. Debris nets are designed to catch small, lightweight construction debris, tools, building materials and other items that may be dropped, pushed or blown from a structure. Debris nets are designed to prevent workers, passersby or traffic from being hurt or damaged. The mesh size of debris nets depends upon the job. They are available in many sizes and strengths depend-



Figure 1. A typical safety net installed under steel workers who are securing a roof beam.

ing on the weight and size of the debris to be contained.

Other safety nets

4. The term “safety net” is frequently used to include any kind of net, whether it is a personnel net, or a debris net. Also, the construction industry tends to categorize nets according to their application (e.g., bridge nets, interior nets, perimeter nets, elevator shaft nets, roofing nets, polar crane nets, etc.). This data sheet will attempt to be specific and define nets according to both type of net and its application.

5. Interior nets are used on the interior of structures where the fall distance is greater than 25 feet. Personnel nets and debris nets are used together on such applications where other means of fall protection, such as flooring or scaffolding, are not used or are not practical. Nets should be cleaned on a daily basis, or as needed, depending on the debris collected.



6. Perimeter nets are personnel or debris nets that are erected around the perimeter of a building to protect workers from over-board falls or to catch construction debris.

7. Other examples of applications for safety and debris nets exist in elevator and mechanical shafts to protect workers and guard against falling debris. Special structures such as cooling towers, chimneys, containment buildings, civic centers, auditoriums, gymnasiums and atriums of large buildings also may be protected with a variety of specialized and special-shaped safety and debris nets.

8. Spalling nets are designed to catch small- and medium-size chunks of concrete or stone that scale off or are being removed from decaying structures.

9. Restoration nets are designed to protect workers, the public, displays and traffic from falling objects during restoration projects.

10. Slag nets are designed to be hung below cutting or welding operations to catch the slag of the welder's or cutter's torch and protect those below.

11. Windscreen/over spray nets are designed to be used vertically to restrict the spreading of paint, sandblast material and sprayed-on insulation while still allowing for ventilation to the area.

Net specifications

12. Only general specifications can be detailed in a data sheet of this kind. Specific data on the various types of nets depends a great deal on the application. The net manufacturer should be consulted for technical data in developing the specifications for a particular job.

13. This data sheet, with the aid of photos, diagrams and charts, will explain the hazards and benefits of safety nets and what measures should be followed in the use and placement of these nets to serve their intended

use best. In addition, recommended minimum design requirements and the usage of nets made with manila rope or with rope or webbing (tape) of synthetic fibers, filaments and their combinations also will be discussed.

Net design

14. Safety nets that meet accepted performance tests may be formed of rope or webbing. Maximum size of mesh openings should not exceed 36 square inches nor be longer than 6 inches on any side measured center-to-center on mesh ropes or webbing. (No mesh opening should exceed 6 inches in length measured center-to-center of mesh crossing.)

15. All mesh crossings should be anchored securely to eliminate friction wear and prevent enlargement of the mesh openings.

16. Each net (or section of it) should have a border rope or bedding of the same quality material as the mesh material. The mesh rope or webbing should be anchored securely to the border at each crossing. The minimum size of the border rope should be $\frac{3}{4}$ -inch diameter for manila and $\frac{1}{2}$ -inch diameter for synthetic; no border rope, however, should have a breaking strength of less than 5,000 pounds when new.

17. Further advances in synthetic material development may introduce additional acceptable materials. (Substitutes should not be accepted without proof of tests indicating at least equal durability, sun resistance, breaking strength and energy-absorbing ability. The tests should meet the minimum requirements of the American National Standards Institute.)

18. Many satisfactory combinations of rope and mesh size are possible in safety net fabrication. Satisfactory performance is the ultimate requirement of safety net qualification. Impact resistance will vary for several reasons.

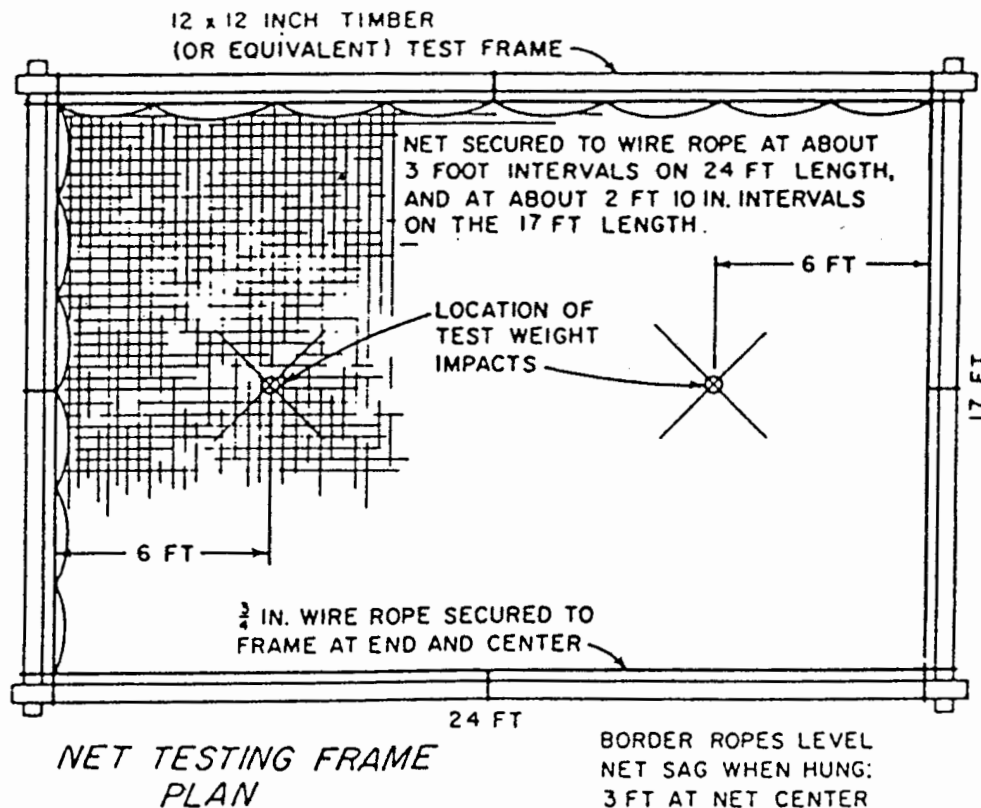

Figure 2. A drawing of a net-testing frame. *Note: The dimensions are given in the English system only.*

- As the overall size between supports of identical net increases or decreases within reasonable limits, the impact resistance will vary approximately in direct proportion to the minimum dimension.
 - As the mesh size decreases, using the same diameter mesh rope, the impact resistance of the net increases.
 - Other pertinent factors are the method of suspension, spacing of ties and securing the border ropes to fixed structures.
- 19.** A prototype test should be conducted by a reliable and independent agency. Qualification as a safety net should be based on the performance of a 17 x 24 foot sample net secured in a frame as detailed in Figure 2. The test frame should provide an opening that is the same size as the net when it is hung and should have sufficient strength to absorb the specified impact

loads, with a maximum deflection in any direction of 4 inches. (A test frame of 12 x 12 inch timbers or equivalent is recommended.) The frame should be elevated sufficiently to prevent the net from contacting any surface or object under the net during the tests.

20. Precautions should be taken so test observers are kept at a distance in the event the test weight bounces out or the net fails.

21. The impact resistance necessary for a net to qualify as a safety net should be such that it absorbs the impact of a 350-pound bag of sand 24 inches (+ 2 inches) in diameter dropped 50 feet into the net and at each quarter-point of the long dimension (6 feet from the end of the net) and the center point of the short dimension (8½ feet from the side of the net). There should be no bro-



ken strands or significant distortion of the net pattern after two drops of the test weight with a 5-minute interval between drops to allow time for net recovery.

22. The net should not sag more than 3 feet at the center of the net (test weight impact point) when hung. Border ropes should be level. A typical tie of border rope to test frame uses $\frac{3}{4}$ -inch manila rope, supported by the frame at ends and center. The net should be supported from the rope at approximately 3-foot intervals, center-to-center, along the 24 foot, 8 inch length (and 2 foot, 10 inch, center-to-center along the 17 foot, 8 inch length).

23. It is accepted in the industry that any net identical in fabrication, except for size, to a prototype net, which has met the specified requirements, may be considered satisfactory for use as a safety net. Each acceptable net shall carry a label with the following information: The name of the manufacturer, identification of the net material, date of manufacture, date of prototype test and the name of the testing agency.

24. For work performed under the sponsorship of the U.S. Army Corps of Engineers, the net requirements given in the remainder of this paragraph are contained in EM 385-1-1, April 1981.2. Safety nets shall be provided when workplaces are more than 25 feet above the ground, machinery, water surface or other surfaces where the use of ladders, scaffolds, catch platforms, temporary floors, lifelines or safety belts is impractical. Nets shall be installed as close under the work surface as practical but in no case more than 25 feet below such work surface. Nets shall be hung with sufficient clearance to prevent user's contact with the surfaces or structures below. Such clearance shall be determined by impact load testing. Only

one level of nets is required for bridge construction.

- Safety nets may be provided where traffic or workers are permitted to be under a work area.
- Nets for overhead protection shall be lined with wire or synthetic netting of not more than 1-inch mesh. Wire mesh shall be made of not less than 22 gage wire and synthetic mesh of not less than Number 18 twine.
- Operations requiring safety net protection shall not be undertaken until the net is in place and has been tested.
- Nets shall extend 8 feet beyond the edge of the work surfaces where workers are exposed.
- The maximum mesh size of nets shall be 6 inches x 6 inches.
- All new nets shall meet accepted performance standards of 17,500 foot pounds minimum impact resistance as determined and certified by the manufacturers and shall bear a label of proof test. Edge ropes shall provide a minimum breaking strength of 5,000 pounds.
- The net suspension system shall be designed and constructed with a safety factor of four and as a minimum shall withstand the test loading without permitting contact between the net and any surface or object below the net.
- Forged steel safety hooks or shackles shall fasten the net to its supports.
- Connections between net panels shall develop the full strength of the net.
- The net installation shall be tested by dropping a 400-pound bag of sand, not more than 30 inches \pm 2 inches in diameter, onto the center of the net from a height of 25 feet above the net or from height equal to the distance from the net to the highest surface for which protection is furnished, whichever is greater.



- Nets shall be tested immediately after installation, relocation or major repair.
- Tests shall be repeated at not more than 6-month intervals.
- Nets shall be inspected daily for cuts and damage from abrasions, chemicals or heat. Repairs shall be made before work above the net is resumed. Rapid loss of strength of small net components should be considered.
- Debris shall be removed from safety nets at least daily and combustible materials shall be removed before welding, cutting, or other operations producing sparks, slag or other ignition sources are done above the net.

25. Nets should be installed as close under the working level as practical and placed with sufficient clearance to prevent contact with surfaces or structures below, when the anticipated maximum impact load is applied.

26. Except under unusual conditions (such as on some bridge construction) where the net placement prohibits normal net erection at 25 feet or makes it impractical, the distance from the highest work level to a net should be no more than 25 feet.

27. When two or more nets are secured together to form a larger unit, the perimeter ropes should be wrapped—that is, laced at not over 6-inch intervals with a lacing rope of a diameter equal to the mesh rope, and securely tied off at every 4-foot interval of the net perimeter. Otherwise, drop-forged shackles or special safety hooks may be used for securement at intervals of not more than 1 foot.

28. The perimeter suspension system should be installed so suspension points are level. Any deviation should slope toward the structure, so that a rebounding load will be guided toward a protected area. When suspended, safety nets should extend 8 feet horizontally from the

outermost projection of the structure. Perimeter nets should follow the work upward and be positioned not more than 25 to 30 feet below any level at which men are working.

29. When wire rope net supports are tied to a structure, the tying intervals should not exceed 30 feet, except for certain types of net rigging used between piers on bridge construction. Wire rope for such purposes should withstand full impact stresses with a minimum safety factor of four.

30. Drop forged steel safety hooks or shackles, which will support the design load, should be used to attach nets to supporting cables, structures or beams projecting from structures. Such attachments should be spaced at intervals of not more than 4 feet.

31. Hanging safety nets inside structures (such as stacks, silos and shafts, or below floor openings) does not present a difficult problem. However, the nets should be arranged to provide easily removed panels that permit the passage of materials being hoisted.

Materials

32. Materials for safety net fabrication should be tested for durability, weather resistance, breaking strength and impact resistance.

33. The materials and fabrication for safety nets, recommended by American National Standard A10.1 1-1979, are as follows:

Section 4.1. Each unit of net width and length equal to 6 x 6 inches shall be fabricated of materials that provide a minimum breaking strength of 4,000 pounds. This may be achieved by the use of $\frac{3}{8}$ inch No. 1 grade pure manila rope, $\frac{1}{4}$ -inch nylon rope, $\frac{5}{16}$ -inch polypropylene rope, 1-inch nylon webbing or their equivalent.

Section 4.2. Materials used shall be compatible with each other.



34. Special precautions shall be taken to shield ropes ½-inch in diameter and smaller from the sun's rays. Ropes of natural or synthetic fibers can lose a significant amount of strength after prolonged exposure to direct sunlight. It is suggested that 6-6 nylon safety netting be dyed with an ultraviolet-absorbing dye stuff of known ability to significantly increase outdoor durability.

When and where to use nets

35. Safety nets should be used when the workplace is more than 25 feet above the ground, water or other surface, such as adjacent structure or intermediate floor. Where the use of ladders, scaffolds, catch platforms, temporary floors, safety lines or safety belts are impractical, nets should be used. (In areas where nets offer the best protection, it might be desirable to have the contract provide for their use, so all contractors can provide for safety on an equal basis.)

36. The U.S. Army Corps of Engineers Manual requires similar protection.

37. Safety nets should be used as overhead protection where public traffic or workers are required to be underneath the work area. In such cases, nets should be lined with wire or synthetic netting of such strength and mesh (which is generally ¾-inch) that, in normal circumstances, falling tools or material would be prevented from falling on persons who may be standing below.

Installation

38. There are as many ways of erecting nets as there are construction jobs. The function of this section is to suggest some basic ideas and some fundamental rules, but the details of safe rigging must be the responsibility of the persons on the job.

39. Look for the most convenient way to

rig a net on every job. Each job is different so that in each case planning is required. Even on two identical jobs, the work sequence may alter the quantity and methods of netting the job.

- Do as much work as possible on the ground, and then hoist the net into position.
- Use a work basket wherever possible to protect the person who must make the high or exposed connections to secure the net. Safety belts with lifelines, boatswain chairs or scaffolding also may be used.
- Planning makes everything easier.
- Nets must be rigged to catch and stop a worker who falls—before he hits another surface or a net support rod.

40. The American National Standards Institute has these installation requirements.

- Nets shall be installed in accordance with the net manufacturer's specifications and instructions.
- Nets shall be installed as close under the working level as practical but not lower than 30 feet and shall be hung with sufficient clearance to prevent contact with the surface or structures below when the user's impact load testing is applied. (Exception: On bridge construction the lowest part of the structure should be considered the highest working surface. It is intended that only one level of nets be required for bridge construction.)
- When two or more nets are secured together to form a larger unit, they shall be laced at not more than 6-inch intervals with a lacing material equal in strength to the mesh rope or webbing. Drop-forged shackles or safety hooks may be used instead of lacing.
- Drop-forged safety hooks or shackles (or other equivalent fastening means) that

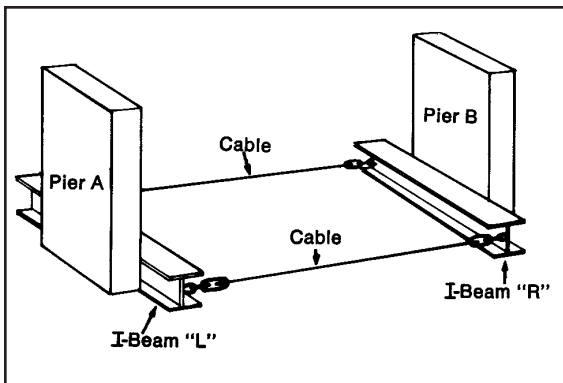

Figure 3. An example of rigging a net under a bridge using the ground method.

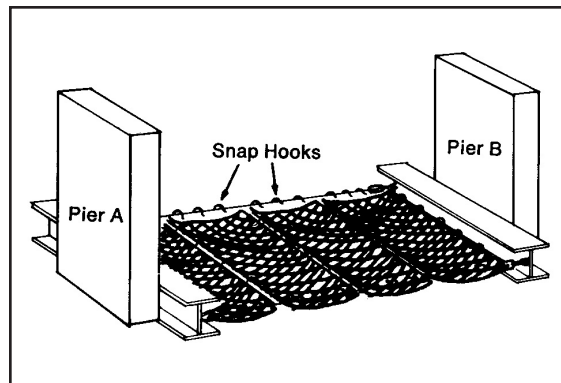

Figure 4. The ground method for connecting nets.

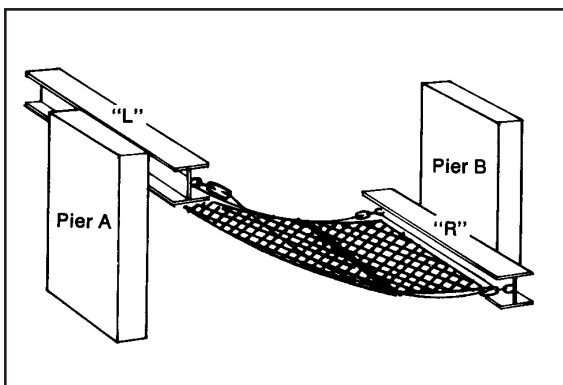

Figure 5. An example of hoisting the eye beam rigging from the ground.

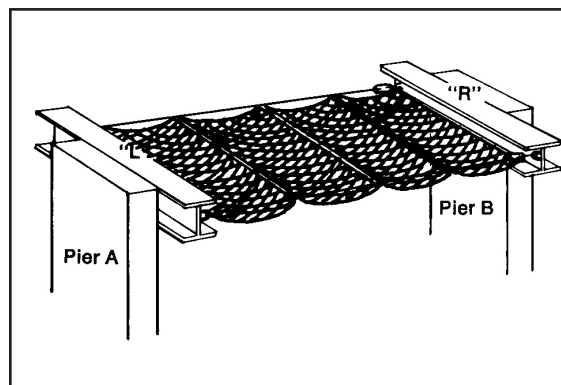

Figure 6. A net that has been raised to position from ground.

will support the design load shall be used to attach nets to supporting cables, structures or beams projecting from structures.

- Safety nets shall extend outward 8 feet horizontally from the outer-most projection of the structure.

Rigging a net under a bridge—ground method

41. Assuming that the span is 100 feet or less, set out one I-beam at the base of each pier. The length of each I-beam should be the width of the bridge plus 16 feet to extend 8 feet on either side of the outside edge of the structure. (Spans greater than 100 feet usually require an extra I-beam in

the center to reduce the sag in the net.)

- Connect the ends of the I-beam across the gap with ropes, one rope on each side (see Figure 3).
- Some nets are designed with a right and a left side. Therefore, spread the nets on the ground across the gap and fasten the span hooks on each net to the ropes and to each other (see Figure 4).
- Fasten the ends of the nets to ropes fastened to the I-beams.
- Hoist I-beam "L" to the top of pier "A" and fasten it to the pier using the inserts that had been previously placed to accept the I-beam (see Figure 5).
- Hoist I-beam "R" to the top of pier "B" and fasten it in place (see Figure 6).



- The net is now in place.
- It is important to have all sides of the net raised so that if a worker falls, he is captured by the net and cannot roll out.

Rigging a net under a bridge—no access between piers

42. Proceed exactly as in the previous example except that all rigging must be done at the base of the pier or on a barge adjacent to the pier. Instead of spreading the nets across the gap, assemble the nets bunched on a rope, accordion-fashion, like a shower curtain folded back upon itself (see Figure 7). In addition, attach a spreader bar to the leading edge of the net. Also attach two lines to the spreader and run them across the gap. The net can be spread across later by pulling the lead lines from the opposite side.

43. It also is possible to feed the lead lines across, around a sleeve on the net-anchoring I-beam and back to pier "A." The net can be spread across by pulling from the pier "A" side of the gap.

44. If a span is too long or the space at the bottom of pier "A" is too crowded to assemble all the nets on one side, half of the nets can be assembled at pier "B" and two sets of lead lines can be used to spread the nets. Then, someone must be

lowered from the center of the bridge in a work basket or harness to clip the nets together at the center.

Curtain nets

45. Occasionally it may be desirable to provide a curtain net for a bridge to protect workers in only the unfinished area, or during a maintenance program. A curtain net is generally not recommended because it is so easy for the workers to forget to move the curtain as the work progresses. Also, very often, the work gets spread over a larger area than the curtain covers, leaving some workers unprotected.

46. A curtain net is rigged on ropes in much the same fashion as shown in Figure 7, and the lead lines are used to move the curtain to the proper location under the work area (see Figure 8). *Important: A spreader bar must be used at both ends of a curtain-type net to keep the ends of the net at the same level as the ropes that support it. Otherwise, it might be possible for a worker who had fallen into the net to roll out the end and fall.*

Rigging perimeter nets on buildings

47. On the ground, in position below where the nets are to be used, assemble the rope, the outrigger bars and sufficient nets to rig one side of the building.

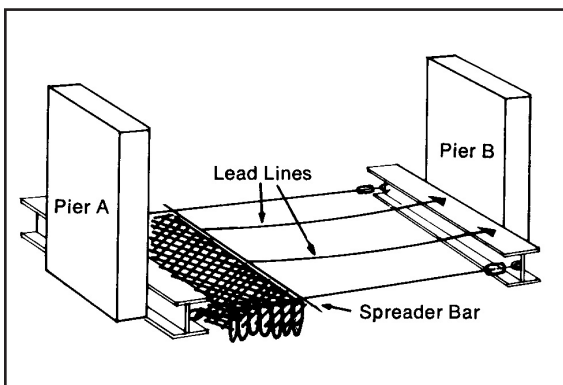

Figure 7. An example of rigging a net under an access between piers.

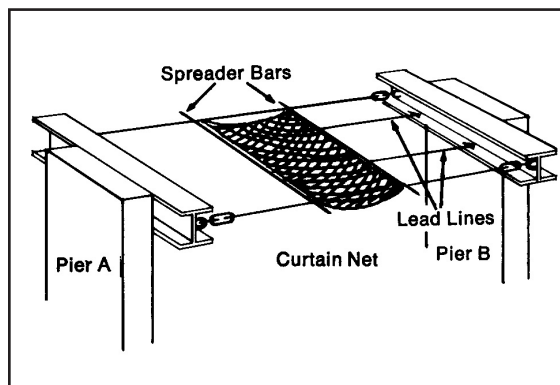

Figure 8. An example of a curtain net rigged for use under a bridge.

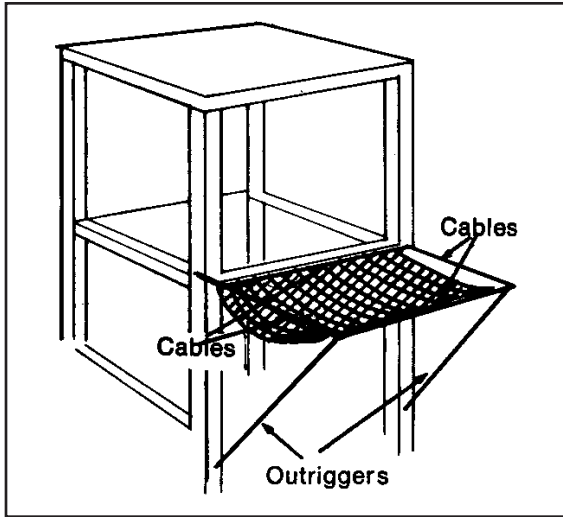

Figure 9. An example of rigging perimeter nets.

- Hoist the whole assembly to the level where it is to be installed.
- Fasten the outrigger bars to the deck of the floor below (see Figure 9).
- Anchor the rope ends in each corner of the building.
- Fasten the inside edge of the net to the floor where the rope is anchored.

- Tighten all connections and the net is ready to be tested.

Decking nets in steel construction buildings

48. The net should go up with the steel. Figure 10 shows one method used by ironworkers. Erect three beams outlining a rectangular bay with ropes for anchoring the nets fastened to brackets welded on the I-beams. Also attach a rope for the net to the fourth beam. On the ground, attach the net to the fourth beam. Then attach the free end of the net to a spreader bar. Lift the entire assembly (the beams, the net, the rope and the spreader bar) into place. The beam completes the fourth side of the bay. Then, two workers starting at "A" and "A," fasten the net to the ropes on the side I-beams and push the spreader bar ahead of them as they crawl along the beams. When they reach the end of the bay, they unhook the net from the spreader bar and hook it onto the rope attached to beam No. 1.

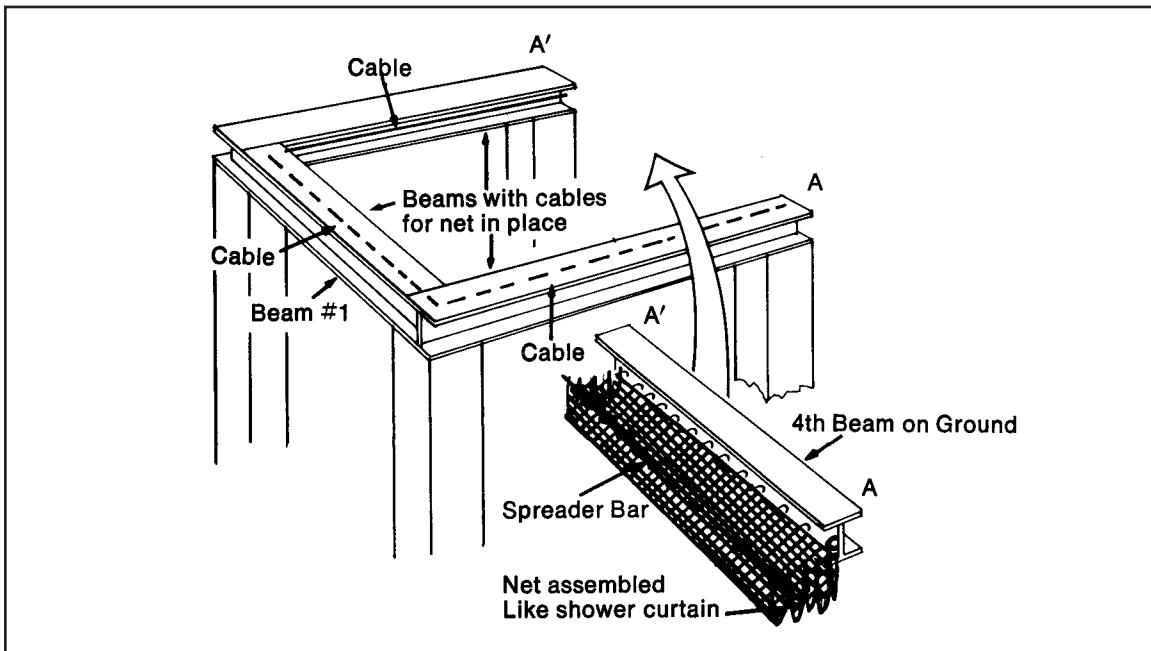

Figure 10. The rigging of decking nets in steel construction.



49. Net panel construction is another method of assembling a safety net. A rectangle of thin-walled aluminum conduit is assembled to act as a spreader on a specific size net. The thin-walled conduit merely shapes the net and fastens to the cable that supports the net. The rope is anchored in the same way as in Figure 10 and the inside edge of the net is clipped to a rope attached to the beam. The advantage here is that the frame provides a convenient way of spreading the net and provides a much more convenient way of moving the nets, formed and in place.

Nets for roofing buildings

50. Figure 11 shows an end view and a plan view of a typical metal building. Ropes, across which personnel nets are hung, are installed along the length of the building to cover each building module. Often curtain nets are used under the section of the roof being assembled. This is permissible only if the roofing operation stops and the nets are moved when the roofing work progresses to within 8 feet of the edge of the net.

Sidewall nets

51. Workers on the edge of a roof should be protected with sidewall nets. Sidewall

nets are suspended from cables that are supported by a bracket fastened to the column as shown in Figure 12. These same nets are used along the end walls as well as the side walls. Figure 13 shows a plan view of nets in place just before the start of a roofing operation. Because sheets of roofing material are installed first from a corner of a building, the end-wall and side-wall nets should be in place as well as the main nets under the roof inside the building, prior to starting roofing operations.

Nets for reactor buildings

52. In the construction of a nuclear reactor building, personnel and debris nets are employed around the outside during rebar welding. Inside, both 4-inch mesh personnel and ¼-inch mesh debris nets are employed under the dome.

Other net applications

Beneath a polar crane

53. A semicircular 4-inch mesh and a ¾-inch mesh net are used in conjunction with and on one side of the polar crane in the containment building. The net is rigged so that it moves with the polar crane and furnishes protection on one-half of the area.

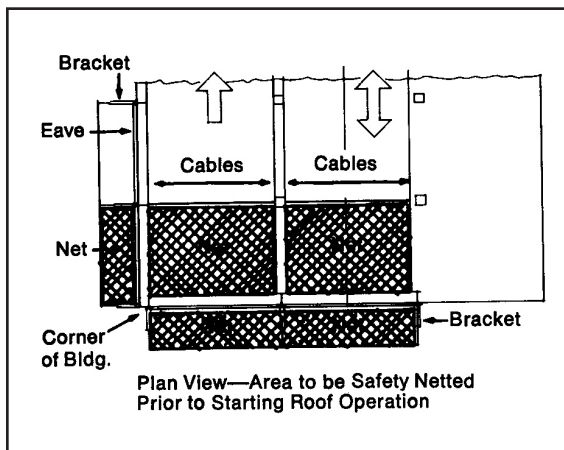

Figure 11. An example of rigging nets for the roofing of a building.

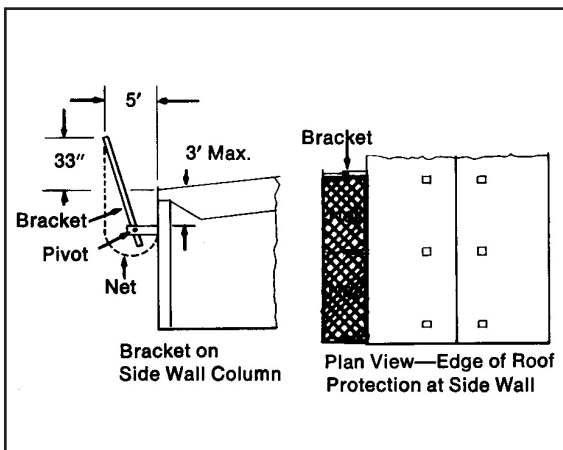

Figure 12. The rigging of sidewall nets for roofing jobs.

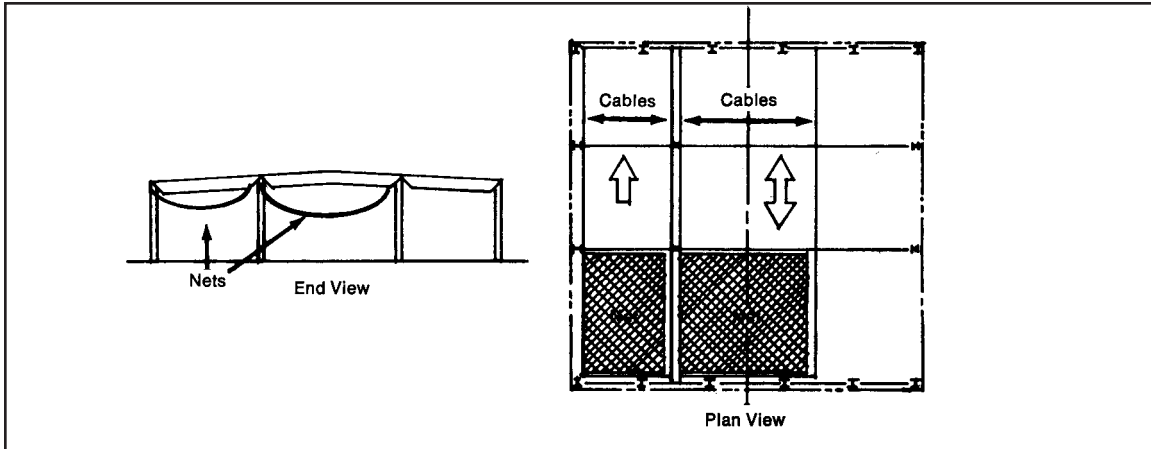

Figure 13. A plan view of an example of rigging safety nets for roofing operations.

The other half of the area is left open to allow materials to be passed up above the polar crane to the workers.

On the turbine pedestal in power plants

54. Personnel nets with 4-inch mesh and debris nets with $\frac{3}{4}$ -inch mesh are used around the turbine pedestal to protect personnel from falling and to protect those below from falling objects.

Power plant boiler cavity

55. The boiler cavity is a large area framed by structural steel. It is open for a long period of time during the erection of a power

plant. Personnel and debris nets are used to protect all the workers in this area throughout the length of the job—steelworkers, electricians, steamfitters, carpenters, painters, etc., (see Figure 17).

Elevator shaft nets

56. Elevator shafts and mechanical chases are dangerous voids in the decks of high-rise buildings and they must be covered. Nets offer the most economical protection: lower initial cost, lower installation cost compared with the cost of materials, time and labor required to construct a wooden platform.

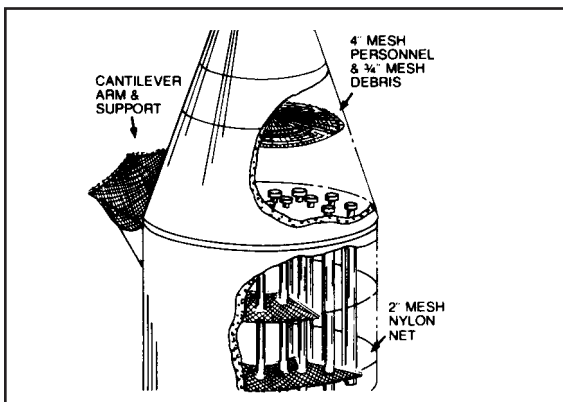

Figure 14. An example of nets in use on a reactor building.

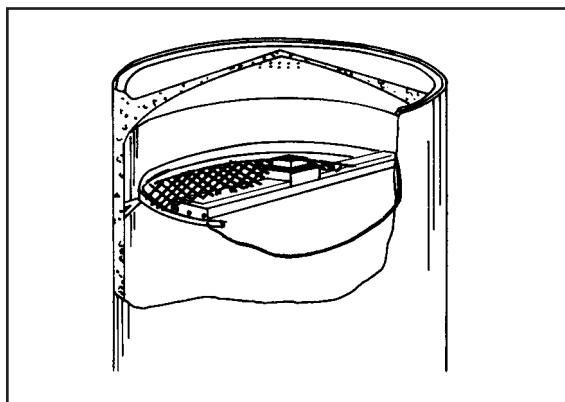

Figure 15. The use of nets on a polar crane.

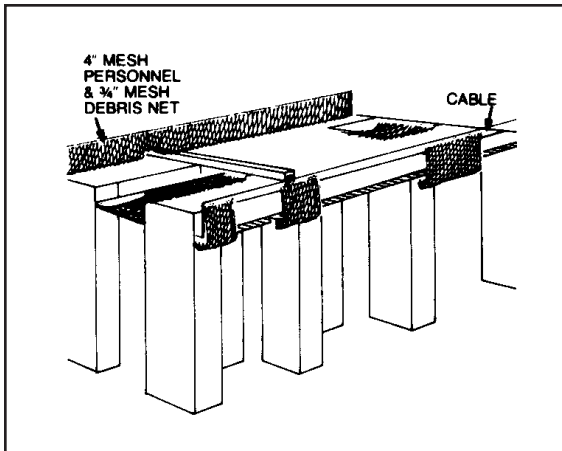

Figure 16. Nets mounted on a turbine pedestal of a power plant.

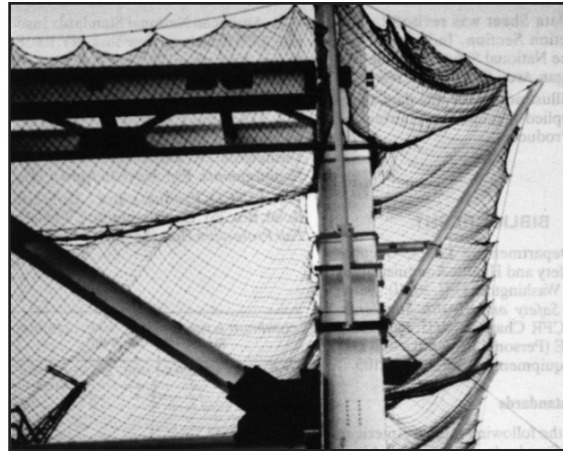

Figure 17. The use of nets to protect construction personnel who are working on the boiler cavity at a power plant.

They also have the following characteristics:

- Lightweight, easy to handle, install, move and store. (A 10 foot x 10 foot net weighs only 10 pounds including hardware). Wooden platforms are heavy and bulky.
- Long life—can be rolled into small bundles and moved quickly from deck to deck and job to job, compared with expendable wooden platforms.
- Offer a “soft catch” in the event of a fall; rigid wooden covers can cause human injury and damage tools.
- Easily moved and replaced by one person (in seconds) for easy access to the shaft, compared with bulky, heavy wooden platforms.
- Allow visibility and permit air, light and sound to pass through.
- Stay in place. Wood platforms may slip and slide or can be blown or kicked out of position and fall.

Inspection

57. Each safety net, mesh rope, perimeter rope, connector, suspension system, etc.,

shall be thoroughly inspected by qualified personnel before and after every installation, and not less than once each week thereafter. Additional inspections shall be made after alterations, repairs, impact loading, and welding or cutting operations are made above the net. Nets that show mildew, wear, damage or deterioration that might affect their strength shall be immediately removed from service for complete inspection and repair.

Job testing

58. Nets and suspension systems should be tested after each installation, alteration or major repair before being returned to service and at 6-month intervals thereafter. If a net is more than 18-months old, a reasonable test interval should be established.

59. Job tests differ slightly from prototype tests conducted by the manufacturer. For nets of normal size, the American National Standards Institute says tests should consist of dropping a 400-pound bag of sand not more than 30 inches \pm 2 inches in diameter from a height of approximately 25 feet above the net into the center of the net.



60. A job should be considered satisfactory if there are no broken members and no significant distortion of net pattern or the suspension system.

Care, maintenance and storage

61. Care, maintenance and storage of safety nets shall be in accordance with the net manufacturer's recommendations with due attention being given to the factors affecting net safety:

- Sunlight affects all fibers, including those commonly used. All nets not in use should be protected from direct and indirect sunlight.
- Abrasion. There is no test that will predict the life of a net under the wide variety of abrasion conditions that may be encountered. The adverse effects of abrasion should be constantly borne in mind. Nets should not be dragged over the ground or other rough surfaces.
- Sand. Embedded sand cuts fibers, reducing the strength of nets. Care should be taken to keep nets as clean and free of sand as possible.
- Rust. Prolonged contact with rusting iron or steel can cause significant degradation and loss of strength. Nets should not be stored in metal containers that are rusty and should be suspended on non-rusting hooks.
- Airborne contaminants. Extremely high concentrations of many chemicals can adversely affect the strength of nets. Where high concentrations may exist, the chemicals should be identified and the concentrations measured. The effect on the net material involved should be determined by test if it is not known.

62. Debris shall be removed from safety nets at least daily, and combustible materials shall be removed before welding, cutting or other operations producing sparks,

hot slag or other ignition sources are done above the net.

63. Repairs to nets should be made promptly and properly by qualified personnel. Defective ropes should be satisfactorily spliced and replaced with new ropes. Dirt and grit act as abrasives and should be removed by washing with clean water. After washing, manila ropes should be dried and re-lubricated with oil recommended by the rope manufacturer.

64. Proper storage of nets is essential. Nets may be stored in dry/shaded areas; they may be hung or folded on pallets. Good air circulation is necessary. Confined dampness is detrimental to manila rope, but does not affect synthetic ropes.

65. All types of nets should be protected against damage from heated surfaces, sharp materials, fungi, rodents and falling objects. Synthetic fiber ropes are not affected by mildew, and the resistance to mildew by untreated manila rope is good except in humid climates. Therefore, a mildew-resistant treatment of manila rope is recommended. Treatment can be applied during manufacture, or nets can be dipped in a fungicide solution at the jobsite.

Fire prevention

66. Manila and synthetic rope nets can be seriously damaged by fire. Therefore, combustible material should not be allowed to accumulate in suspended nets, as emphasized in paragraph 62. When riveting, welding or burning is done above nets, they should be under constant observation. Serious damage has resulted when welding slag has fallen into nets piled or rolled up under construction work. Nets hung vertically when stored are least exposed to these overhead hazards.

67. Manila rope is fire-resistant to a degree and does not support combustion under



normal conditions. However, fire-retardant treatments have not proved practical when nets are exposed to the weather. Furthermore, application of fire-retardants to synthetic ropes is of no value, because these ropes will melt instead of burn when exposed to heat.

Sources of information

American National Standards Institute, 1819 L Street, 6th Floor, Washington, D.C. 20036. *Safety Nets used During Construction, Repair and Demolition Operations*, ANSI A10.11-1979.

OSHA, Washington, D.C. 20210: *Occupational Safety and Health Standards*, Title 25 CFR Chapter XVII, Part 1926. Subpart E (Personal Protective and Life Saving Equipment), Section 1926.105.

U.S. Army Corps of Engineers, Department of the Army, The Pentagon, Washington, DC 20314. *Safety and Health Requirements*. EM 385-1-1, April 1981.

SINCO Products Inc., 3965 Pepin Avenue, Red Wing, MN 55066. *Fall Protection Handbook*, 4th ed., 1982.

Related standards

When the following related American National Standards are superseded by a revision approved by the American National Standards Institute the revisions should be used.

Safety Requirements for Personnel Hoists, ANSI A10.4-1981.

Safety Requirements for Material Hoists. ANSI A10.5-1981.

Safety Requirements for Demolition, ANSI A 10.6-1969.

Safety Requirements for Scaffolding, ANSI A 10.8-1977.

Safety Requirements for Concrete Construction and Masonry Work, ANSI A10.9-1982.

Safety Requirements for Window Cleaning. ANSI A39. 1-1969.

Manually Propelled Mobile Ladder Stands and Scaffolds (Towers), ANSI A92. 1-1977.

Vehicle-Mounted Elevating and Rotating Aerial Devices. ANSI A92.2-1979.

Acknowledgment

This data sheet was prepared by the Construction Division of the National Safety Council, 1121 Spring Lake Drive, Itasca, IL 60143.

Copyright ©2007 National Safety Council. All rights reserved.

Although the information and recommendations contained in this publication have been compiled from sources believed to be reliable, the National Safety Council makes no guarantee as to, and assumes no responsibility for, the correctness, sufficiency or completeness of such information or recommendations. Other or additional safety measures may be required under particular circumstances.